

1/4" - Whitworth (INSERT SCREW)

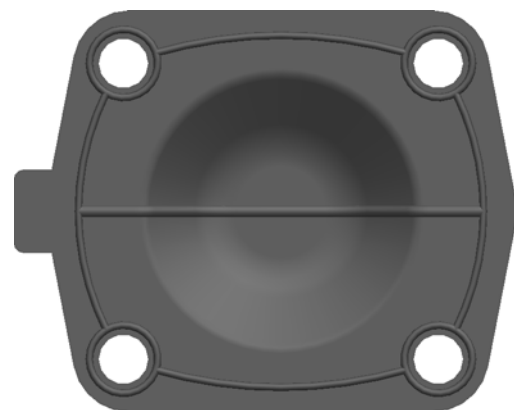

REVISION HISTORY			
REV	DESCRIPTION	DATE	APPROVED
B	OEM PART changed from 2.000-D to DA050B1	27/02/22	JB

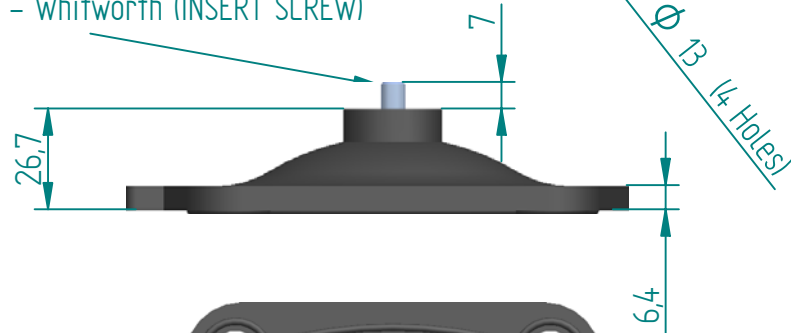
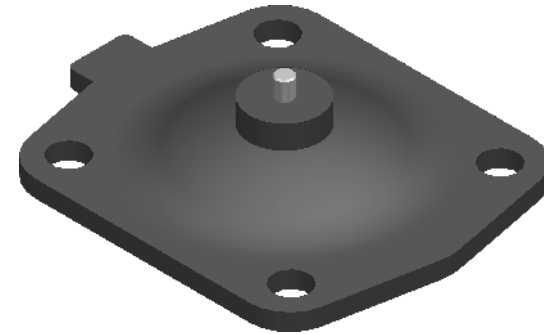

SCALE  
1:2



Replacement Diaphragm for :-  
OEM PART = DA050ER  
USED ON 2" (DN50) Diaphragm Valve

	NAME	DATE
DRAWN	M.MC KEON	02/27/22
CHECKED	M.MC KEON	02/27/22

**Material -BUTYL(IIR)**

Complies with CFR 177.2600  
and Conforms to  
USP Class VI Biological Reactivity  
Tests Section #87 and #88



TITLE  
**DD20-SIIR-B**

SIZE A	<b>FOOT PRINT DIMENSIONS</b>	REV B
-----------	------------------------------	----------

FILE NAME: DD20-SIIR-B.dft

SCALE: 1 : 1.25 SHEET 1 OF 1

Disclaimer - Diaphragm Direct® does not manufacture, represent, nor sell OEM valves or diaphragms manufactured by any other company. Diaphragm Direct® brand diaphragms are not sponsored by any other manufacturers. Any name, model, part number, brand, image, material or referral is for descriptive purposes only. Diaphragm Direct® brand replacement diaphragms are guaranteed to fit OEM equipment and meet or exceed OEM specifications. Diaphragm Direct® brand replacement diaphragms are covered by the standard Diaphragm Direct® limited product warranty.